



Solid Solutions. Smart Lighting.

Veko | Renovation



Veko | Renovation

Is your production hall, distribution centre or sports hall equipped with lighting from Veko that was supplied sometime in the past few decades? Then renovation of your commercial lighting could be a wise decision.

Support profiles remain in place

Our support profiles are produced from sustainable aluminium, so the internal cabling remains intact. By simply replacing the luminaires, you can create a brand-new, contemporary LED lighting system. If you also opt for dynamic switching, you can save even more energy.

No Veko commercial lighting?

Renovation is still a smart move

Is your current lighting system from a different supplier? Our experienced, SCC-certified installation teams will be happy to renovate your lighting system in no time, and with no inconvenience, to create a Veko system. Your new system will be future-ready: if you ever have to repurpose or redesign your premises, and different demands are required on lighting in the new situation, your Veko lighting system can easily be re-used. Lighting systems

from most other suppliers would have to be replaced entirely.

Free test layout? To measure is to know!

We will be happy to calculate your potential savings if you decide to renovate your commercial lighting system. We will install a test layout with new Veko LED luminaires, completely non-binding obligation. Your staff can decide whether or not they feel comfortable working beneath Veko lighting while you can measure the energy consumption.

Total Cost of Ownership

Based on Total Cost of Ownership (TCO), you have a clear overview of both the initial investment and the energy costs for the future. TCO helps you identify the ideal types of luminaires, sensors and/or the light management system.

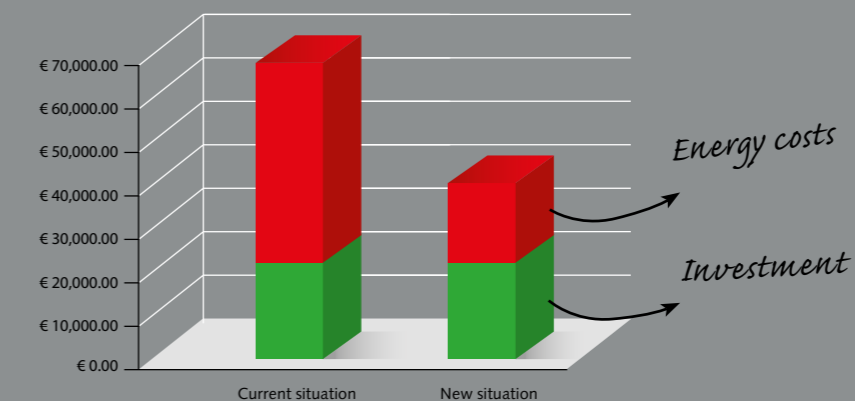

Good lighting is the starting point

In renovation projects, it is important that we optimise your Veko lighting system without incurring unnecessary costs or wasting materials.

The Veko aluminium profiles are designed in such a way that they offer an extremely long lifecycle and can be fitted with several generations of Veko luminaires. Even when replacing the old luminaires 1-for-1, in most cases, it is not necessary to remove the 7-core flat cable from the profile. The profiles can be easily exchanged via Click-out Click-in.

Narrow

The Narrow delivers a targeted beam, ideal for aisles between storage racks. In combination with the ideal lumen output achieved via Veko Tune, you can achieve perfect light balance, even at heights up to 25 metres.

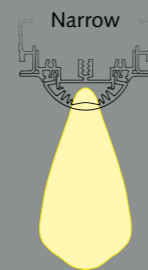

Semi Wide and Wide

The Semi Wide and Wide lenses have been developed not only to illuminate the aisles but also the storage racks. The choice of lens depends on the aisle width.

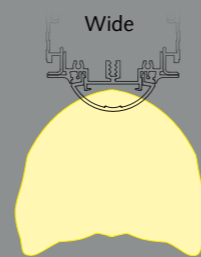
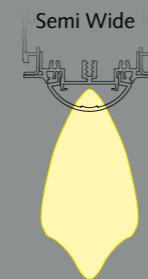

Circular and Diffuse

The Circular and Diffuse lenses are intended for use in open spaces. For areas requiring low blinding levels, simply choose the Diffuse lens. For more general lighting and higher efficiency, the Circular lens is the perfect choice for your project.

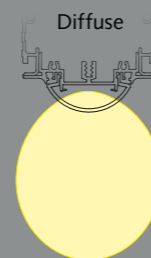
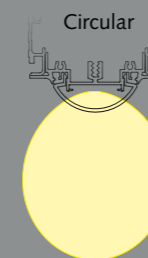

The light line in detail

We configure our light lines for every project. The light lines are designed stepwise, depending on the conditions required. In this way, we create a unique product, adapted to your project. This effect can be achieved with new light lines or by renovating existing Veko light lines.

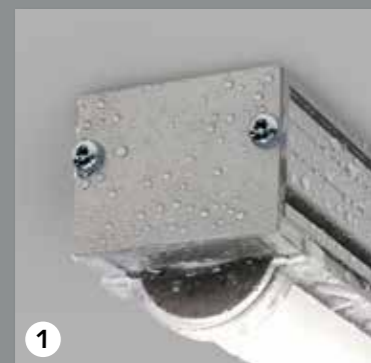

A smart system

The Veko light line is a profile system designed individually for each project. This enables you to create the ideal combination of continuous light lines interspersed with presence detection. (De) central emergency lighting and spotlights can be easily added. If you opt for a profile with cable duct, other (data) cables can easily be integrated.

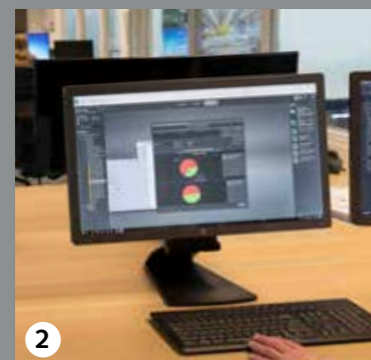

Encelium light management system

Using the Encelium light management system (from Osram) you can easily manage your (emergency) lighting and sensors. The system generates reports with fault messages, the latest energy consumption data and energy savings, all visualised in a 3D plan.

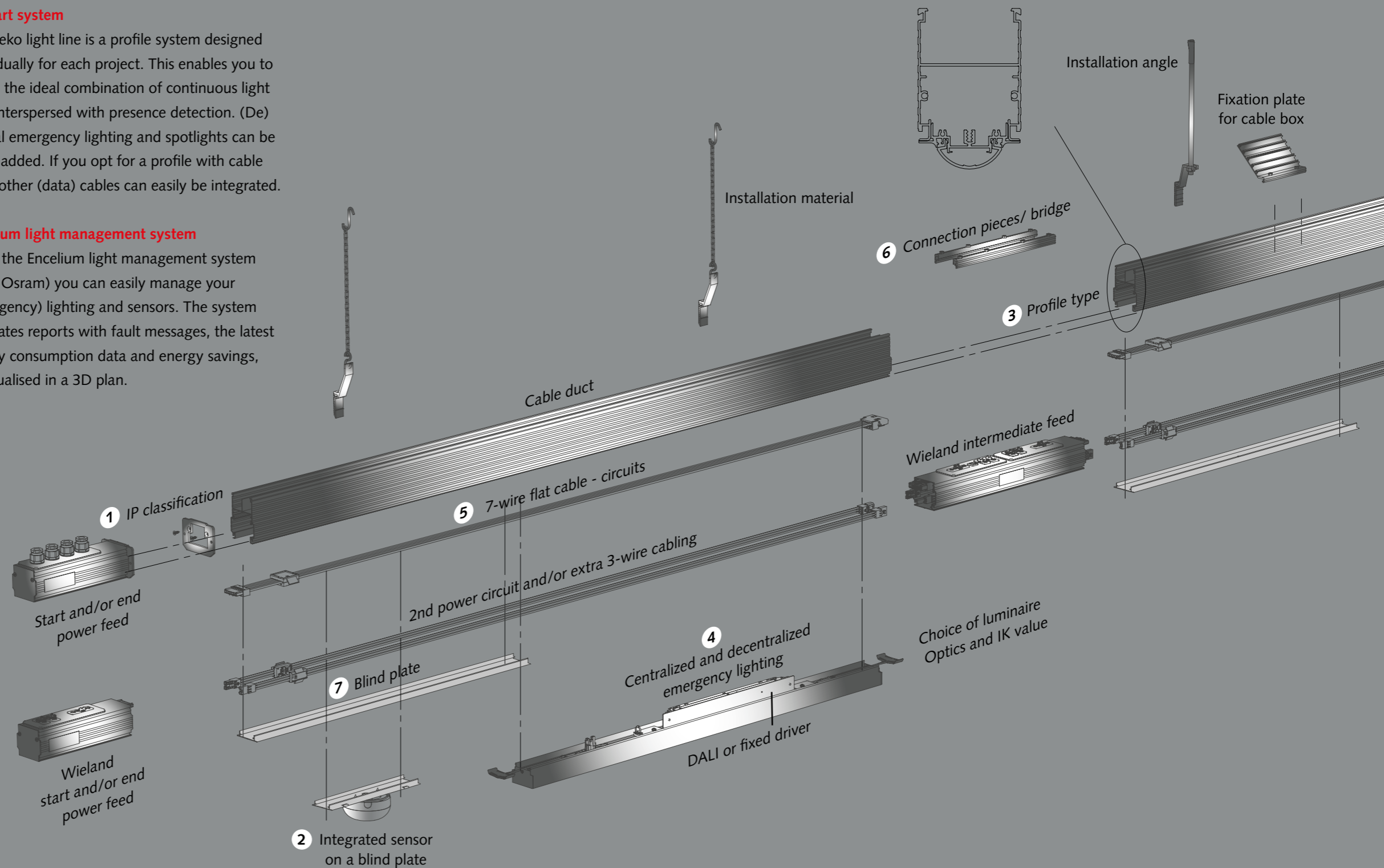
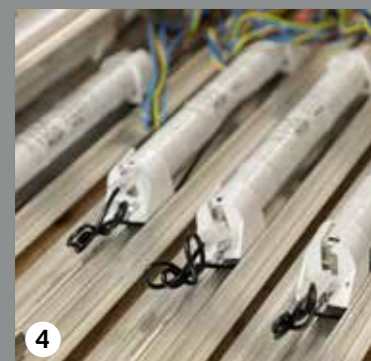
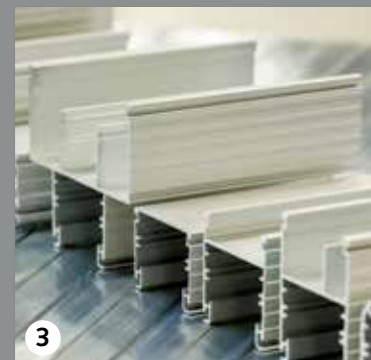

From design to maintenance

Veko are specialists in linear lighting. The company develops and manufactures LED lighting in-house. As far as possible, we remove all our customers' cares and deliver turn-key projects. From application to maintenance, you can rely on the specialists at Veko.



Development

Every day, a team of designers and product engineers at Veko is working very hard developing, testing and producing the latest industrial lighting products. Veko aims to deliver the ideal lighting solution for every factory hall, sports hall, carpark, refrigerated and frozen storage location and retail environment. Through the use of separate lenses, Veko identifies the ideal optical solution. One special feature is that whereas Veko used to purchase all components, the company now manufactures the light sources itself, in combination with smart switching systems. Thanks to Veko Tune, luminaires are adapted precisely to your specific wishes.



Production

Veko operates a modern factory and also manufactures its own LED strips. Veko even produces 1.5 metre-long LED boards eradicating annoying interruptions in the lighting pattern. In the factory in Schagen, luminaires are produced on a project basis and delivered fully prefabricated.



Installation

Engineers at Veko work in fixed teams and take up the challenge to install your lighting as efficiently as possible. Because they handle linear lights on a daily basis, and the systems are delivered plug and play, you experience minimal nuisance on the shop floor and save up to 50% on installation times.



The Veko team will also be happy to remove your existing lighting. This fact, combined with the minimal use of packaging material guarantees that your location can be put back into action quickly and cleanly.

Service and maintenance

If something does go wrong with your system, the service staff are permanently on call. Veko handles all light disruptions from a central location, guaranteeing rapid, adequate assistance.



Reference projects

Over the past few years, Veko has completed numerous eye-catching projects based on our innovative luminaires, backed up by the latest technology. We are proud to share the results and findings of our customers.

DHL distribution centre

Over the past few years, Veko has completed numerous eye-catching projects based on our innovative luminaires, backed up by the latest technology. We are proud to share the results and findings of our customers.

IKEA home store

IKEA wanted to install LED lighting, and compared a number of potential suppliers. The lighting was thoroughly tested. Veko came out on top thanks to its light quality, energy consumption, sustainability and service.

Nissan distribution centre

Overloading meant that the group cabinets at Nissan were overheating. To solve the problem, Veko suggested lower power LED luminaires. This resulted in lower energy demand and heat production while lighting quality was visibly improved.

“For our recent renovation project we extensively tested and measured LED lighting from various different manufacturers. The IKEA Distribution Centre in Genk opted for Veko on account of the light quality, energy consumption, durability and service they provide.”

Jurgen Poelmans, Facility & Sustainability & IT,
IKEA Distribution Benelux NV



Solid Solutions. Smart Lighting.

www.veko.com