

MD-L-R ADVANCED RELAY

IP20 - IP54 - IP65

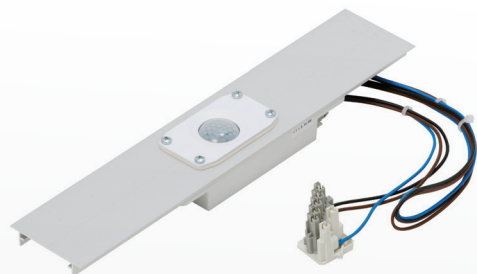

The waterproof MD-L-R Advanced Relay presence detector performs outstandingly in combination with Veko industrial lighting in open areas. Because of the detection angle and a combination of useful features, you can achieve maximum energy savings with this motion sensor. Not a single motion goes unnoticed by the extremely sensitive infrared (PIR) sensor of the MD-L-R Advanced Relay, which registers and interprets changes in the thermal image extremely quickly.

The MD-L-R Advanced Relay detector has various settings for detection sensitivity, turn-off delay and twilight sensor. A convenient remote control allows you to set the detector at the levels that suit you. Your lighting will not be on for example if there is enough daylight and will switch off, with a delay, when there is no more motion. You will always have the exact required amount of illumination everywhere.



Technical information

Length (mm)	300 mm
Wattage (W)	0.5 W < 4 W (off < on)
Voltage (V)	220 - 240 V
Frequency (Hz)	50 ÷ 60 Hz
Circuit	6A
Sensitivity settings	5 (standard maximum sensitivity)
Twilight sensor	Adjustable in 9 steps 0 – 1,000 Lux
Turn-off delay relay	Relay 1 - 99 minutes
Ambient temperature	-25 °C - +35 °C
Corridor function/dynamic switching, e.g. 10-100%	In combination with DALI driver and ballasts
Programming	Readable and reprogrammable by colour coding with LED in the sensor
ENEC certification	Has been requested by DEKRA
Warranty	5 years

Accessories

Remote control	Order code
	TR67

Technical data subject to change.

Measurements

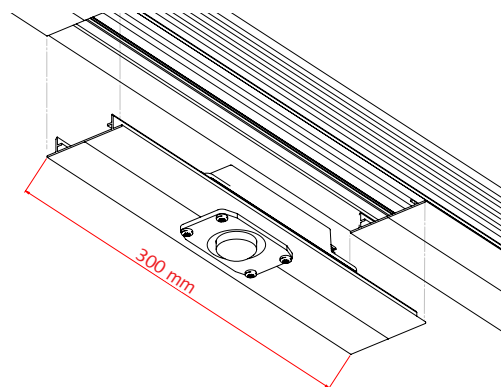

Detection range

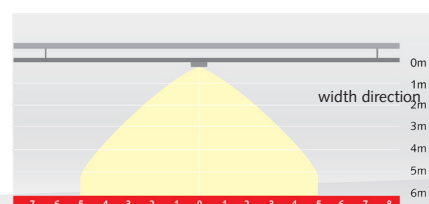
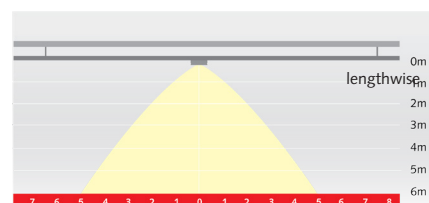

CLEVER
SWIFT
SOLID